

Powder Fire Extinguisher kg 9 Class of fire 55A 233B C

with internal cartridge EN3 conformity certificate nr. 46-2008

EC Approved Certificate: CE-1370-PED-H-ABS001-09-ITA



55

Organic solid materials, wood rubber, textiles etc.



233

Flammable liquids, gasoline, oil etc.



Flammable gases, methane, propane.

CYLINDER, CE MARKED PED 2014/68/UE

The design cylinder is manufactured according to the Pressure Equipment Directive PED 2014/68/UE and "CE marked"; the welding process and the welders' qualification is made according to the EN 288 and EN 1418.

Tests are made according to the EN3 and EN 3-3 which require for each batch bursting and crush test etc.

The cylinder is designed to work from -30°C to +60°C.

The cylinder is manufactured in 3 pieces with two domes (upper and lower) steel type DD12, one cylindrical shell, steel type DD12 and the neck gear steel type S235J2G3.

The cylinder is welded by means of a MIG machine with electronic control of: speed, flow of the gas mixture, voltage and amperage. All these controlled parameters, guarantee quality and uniformity of the welding, the steel is supplied with chemical and mechanical certificate 3.1.B EN 10204.

Each cylinder is "CE" marked according to directive PED 2014/68/UE. Each cylinder is leakages tested moreover hydraulic tested up to 26-bar for thirty seconds. Before painting it is cleaned with a deep sand blasting assuring a raw surface for a perfect and strong grasp of the epoxy polyester powder coating red RAL 3000 u.v.

VALVE M74x2

The valve is brass made with knob and handle. Complete with spring safety valve. Provided with safety pressure release device during accidental unscrewing from cylinder neck gear. A green safety seal on the valve improves the optical checking and integrity from far distance.

DISCHARGE HOSE

Made of reinforced rubber with plaited textile reinforcement, complete with galvanized brass fittings, automatically clamped. The hose is tested according to EN3, the burst pressure is over 54 bar.

INTERNAL CARTRIDGE

Capacity 210 g, high pressure seamless steel, tested at 250 bar.

EXTINGUISHING AGENT

Dry chemical powder top quality German product according to EN 615 and ISO 9000 quality control.

The basic components of dry powder are ammonium phosphate and ammonium sulphate with special silicones additives enabling easy flow discharge and avoiding any caking process. Dry powder is not corrosive, not abrasive, not toxic for humans and animals.

Note: other kinds of powder may be used instead of ABC40: ask our technical office for compatibility.



Made in Italy

CO₂ internal cartridge

The wall bracket keep the fire extinguisher close to the wall



Labels available: English, French, German, Arabic, others

USE

This extinguisher can be used on all the types of fire classes A B C and also on electrical equipment up to 1000 Volt at 1 m distance minimum. In laboratory the extinguisher succeeded the dielectric test at 35 KV at 1 mt distance.

- 1) Pick up extinguisher
- 2) pull out safety pin
- 3) keep the pistol in one hand, press upper knob, squeeze lever on the pistol, aim jet at fire base and sweep with pistol.

In case of fire of inflammable liquids don't approach too much, keep yourself distance in according to the local regulations. In some countries training is compulsory to use the extinguisher.

MAINTENANCE

Check weight of CO₂ cartridge every year. Check obstructions into the nozzle and into the hose; if any, clean them with compressed air. Check if pin and seal are intact. Check integrity of safety disc. Even after partial use the fire extinguisher must be refilled. Refill with a fresh new 9 kg powder original ABC 40% MAP. Check hose integrity, if cracked due to aging retest at 20 bar or replace it with a new one.

Technical specifications

Internal cartridge : **CO2 cylinder 210 gr**
 Extinguishing agent : **Powder ABC40**
 Nominal charge : **9 kg**
 Discharge time ~ : **19 sec**
 Jet length ~ : **7 m**
 Operating pressure ~ : **11 bar at 20°C**
 Test pressure according PED 2014/68/UE : **26 bar**

Burst pressure : **>55 bar**
 Temperature range : **-30°C +60°C**

Dimensions

Height ~ : **545 mm**
 Width ~ : **320 mm**
 Diameter ~ : **190 mm**
 Weight ~ : **16 kg**

Spare part list

Pos.	Description	Code	Q.ty
1	Complete valve	20040	1
2	Safety pin	20091	1
3	Safety valve	21131	1
4	Safety nut	21019	1
5	Oring of valve	20038	1
6	Siphon tube Steel pres	20728	1
7	Internal cartridge 210 gr	20208	1
8	Siphon tube PVC discharge	21714	1
9	Or discharge hose connection	20037	1
10	Discharge hose	20659	1
11	Cylinder (13.4 lt) CE mark (optional stainless steel)	27703	1
12	Powder ABC 40	31240	9 kg
13	Safety seal	28019	1
14	Extinguisher bracket	20052	1
15	Wrapper band	28025	1
16	Clip hose holder	20098	1
17	Pistol	21035	1
18	Plastic foot (optional) available steel foot ring	21049	1



EN3/7



Made in Italy

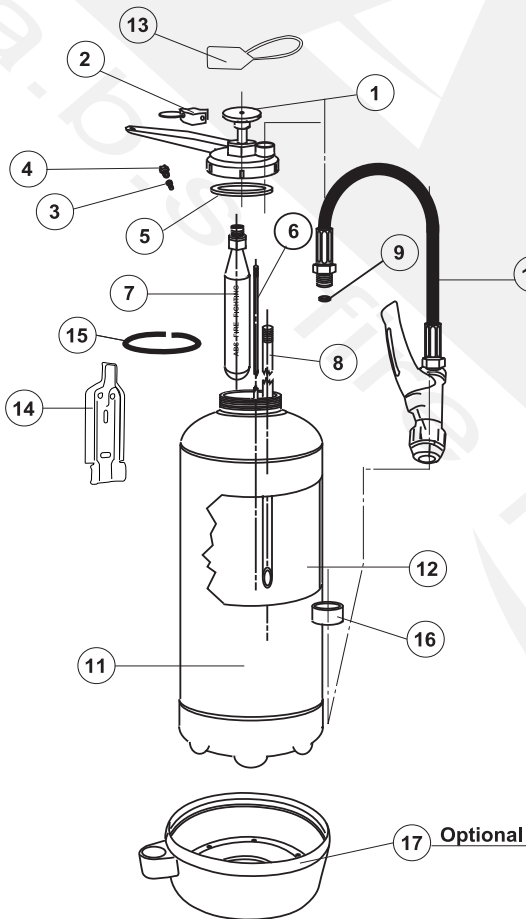

Optional Brackets



The use of non original spare parts may cause malfunctions loss

Maintenance and Guarantee

Maintenance must be made periodically by, trained and certified staff, according to the local regulations of the country where it is located. The extinguisher is guaranteed for 12 months from the date of the supply. The guarantee includes, repairing or replacement, as manufacturer option. Unit must be sent back to the factory free of charge, only when authorized written agreement with our sales office has been reached. The guarantee expires in case of tampering and bad maintenance made by not-authorized staff, or transport damages. It must be recharged only by staff authorized and certified by **a.b.s. S.r.l.**, use only genuine original spare parts.