

Gamme TITAN EN 1866-1

Très maniable et extrêmement efficace sur les départs de feux de tailles significatives.



Grande ouverture de $\varnothing 90$ mm permettant une vérification annuelle telle que le demande la réglementation.



Bouteille en acier forgé et robinetterie en laiton



Roue en caoutchouc DN 300



Support et embout permettant d'enrouler le flexible et de loger la lance



Lance mitrailleuse avec ressort anti-cassure



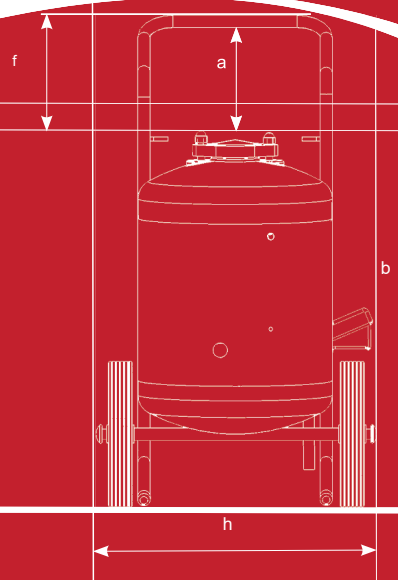

Grand couvercle en fonte d'aluminium avec un gros joint d'étanchéité pour plus de sécurité

Efficacité prouvée : le taux résiduel après utilisation est inférieur à 5 % alors que la norme EN1866-1 tolère 10%.



EN 1866-1





Type d'extincteur	T50ABC
Numéro de rapport	GL 18 0006
Portée	6,2 mètres
	A
	II B
	C
Agent Extincteur	50 kg Poudre ABC 40 / P1124
Agent propulseur	1000 g CO ₂
Dimensions	1000 x 550 x 575 mm
Poids	95 kg
Longueur de flexible	5 mètres
Température	-20°C +60°C
Code article	XR-ZT50ABC



Extincteur Poudre ABC



Type d'extincteur	TA45	TAA45 (Antigel)
Numéro de rapport	GL 18 0005	GL 22 0001
Portée	5 mètre	
	A	A
	III B	III B
Agent Extincteur	45 L eau + additif	45 L eau + additif +Inilam BT35
Agent propulseur	500 g CO ₂	
Dimensions	1000 x 550 x 575 mm	
Poids	95 kg	
Longueur de flexible	5 mètres	
Température	+5°C +60°C	-10°C +60°C
Code article	XR-ZTA45	XR-ZTAA45

Extincteur Eau

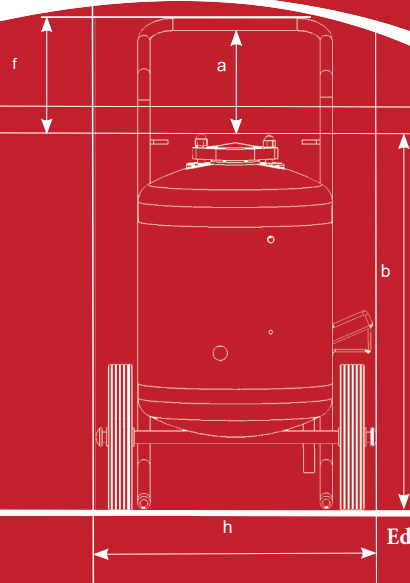

Edition Avril 2024